

# SEPHRA<sup>®</sup>

CATERING EQUIPMENT AND SUPPLIES

## WAFFLE MAKER OPERATING MANUAL

VERSION 2.0.4 JULY 2021

Sephra are your one-stop shop for Waffle Machines,  
Consumables, Spare Parts and Repairs.



# TABLE OF CONTENTS

3	TABLE OF CONTENTS
4	IMPORTANT SAFEGUARDS
5	THE LEGEND OF SEPHRA
6	DEAR SEPHRA CUSTOMER
7	TECHNICAL DESCRIPTION
7	APPLIANCE INSTRUCTIONS
8	BEFORE FIRST USE
9	OPERATING INSTRUCTIONS
10	REPLACEMENT PLATE (6) INSTRUCTIONS
11	EUROPEAN READY MIX & CLEANING GUIDE
12	USA READY MIX & CLEANING GUIDE
13	AFTERSALES GUARANTEE

# IMPORTANT SAFEGUARDS

Before using this appliance please make sure that you have read through this manual and paid particular attention to the safeguards that are listed below.

- This appliance is not to be used by persons (including children) with reduced physical, sensory or mental capabilities, or lack of experience or knowledge, unless they have been given supervision or instruction.
- Children being supervised not to play with the appliance.
- The appliance must never be left without supervision during use.
- Do not use the appliance for anything other than the purpose, which is described.
- There is a risk of accidents if accessories are used that are not recommended by the manufacturer of this appliance.
- This appliance should always be plugged into its own individual electrical outlet which has proper supply voltage, properly grounded and one that can handle the wattage rating that is identified on the rating Plate (6) on the back of the unit.
- Check the power supply cable regularly in order to detect signs of deterioration.
- Do not connect nor use any appliance with a damaged plug or cable. If the supply cord is damaged, it must be replaced by the manufacturer, its service agent or a similar qualified persons in order to avoid a hazard.
- In case of failure, the examination and repair should be performed by a qualified technician.
- All maintenance must be performed by a qualified technician.
- The appliance is not designed to be switched on by an external timer or separate remote control system.
- If you need to use an extension lead, take care to unravel the whole length in order to avoid the cable overheating.
- Always connect or disconnect the cable to the power socket with the Thermostat (1) knob set at the off position.
- Do not place the appliance on a wet surface. Do not immerse cord, plug, or appliance in water or liquids to protect against fire, electrical shock and injury to persons. Do no handle the appliance with wet hands.
- Do not let the cord hang over the edge of a table or counter.
- Do not put the appliance or its cable on or near a hot surface (electrical hotPlate (6), hot gas burner, heated oven etc.).
- Disconnect the plug when the appliance is not in use and allow to cool before cleaning.
- The appliance must not be cleaned with a high or low-pressure jet.
- Do not bleach.
- Do not handle the appliance while hot.
- Do not touch the hot surfaces.
- Leave the appliance to cool prior to handling or cleaning it.
- Place the appliance on a dry and stable surface, and slightly back from the edge and at least 20 cm from any wall or element liable to be affected by heat.
- Take care: Do not insert a sheet of tin foil or any other material or object (risk of damage) between the Plate (6) and the frame (ventilation area).
- Ensure the ventillation louvres of the machine are clear at all times during operation.
- Caution: Do not use this device with wood, coal or other energy source than that for which it provides (electrical energy)
- We recommend you keep the original packaging in order to store the appliance.

Please make sure that you save these instructions whether for you intend to use the appliance for Domestic or Commercial purposes.

## THE LEGEND OF SEPHRA

Woven among the threads of ancient Aztec legend lies the story of Sephra, an enchanting goddess whose beauty could be described only as the richness of the dark earth combined with the lustre and glow of pure gold. Her voice was softer than the most delicate flower, and her presence carried the aroma of sweet cocoa. It was Sephra who gave the ancient Aztecs the precious gift of the cocoa tree.

The legend reveals that the spirit of Sephra nourished the cocoa trees and lived within the priceless beans they produced. The Aztec kings named the cocoa tree “Theobroma Cacao,” meaning “food of the gods.” So valuable were cocoa beans that they were used to pay tribute to royalty and were given as sacred offerings to the gods.

Montezuma, the ruler of the wealthy Aztec Empire, was so enchanted by Sephra that he commissioned an elite force of skilled artisans and master craftsmen to construct a temple in her honour. As a special offering to the goddess, Montezuma built a magnificent fountain in the highest room of the temple and filled it with glistening spring water, which flowed from beneath its walls. He then surrounded the fountain with a splendid array of the most perfect cocoa beans, in hopes that Sephra would continue to bless the people with the unique and valuable crop.

So pleased was Sephra with Montezuma’s gift that she came to him in a dream and told him that her spirit would always live in the fountain he had given her. Moments later, Montezuma awoke to the sweet smell of cocoa lingering in the air. The aroma led him to the upper room of the temple where Sephra’s fountain stood.

To his astonishment, the fountain no longer flowed with water, but with the richest, purest chocolate... this was truly a gift from the gods.

For centuries, Sephra’s fountain remained hidden beneath the ruins of the ancient Aztec temple, waiting to be discovered. At long last it was, and with it was unveiled the secret of the pure, rich chocolate once coveted by gods and kings . . .

© Sephra Europe Ltd



# DEAR SEPHRA CUSTOMER

Thank you for choosing one of our appliances. It is very easy to use and we do strongly recommend that you carefully read these instructions which include advice on how to use and install your appliance in order to obtain optimum results.

## RECEPTION AND UNPACKING

Any product damage due to transport must be reported to the carrier by registered letter with acknowledgement of receipt within 24 hours of receiving your appliance. You must also note your observations on the delivery note, describing in detail the damage noticed on delivery.



### ORDERING AND CONTACTING (240V)

You can order all you need for your appliance by contacting us on +44 (0)1592 656 737.

Purchase online by visiting our company website: <http://www.sephra.com>.

Any direct queries can be sent to: [info@sephra.com](mailto:info@sephra.com).



### ORDERING AND CONTACTING (120V)

You can order all you need for your appliance by contacting us on +1 858 675 3088.

Purchase online by visiting our company website: <http://www.sephrausa.com>.

Any direct queries can be sent to: [info@sephrausa.com](mailto:info@sephrausa.com).

Our mission is to help you make your Sephra appliance a very profitable aspect of your business and we look forward to assisting you.

Thank you for choosing Sephra!

The Sephra team

# TECHNICAL DESCRIPTION

These models are designed for professional use. Strong and reliable, they are convenient to use thanks to the constant temperature, even and fast cooking.

This Waffle Maker has two models (110VAC & 240VAC) for different international markets. The heavy-duty Waffle Maker's space-saving design includes a stainless steel housing, an aluminium heating pedestal and aluminium Baking Plates (6) treated with Teflon™ coating. Baking temperature and timing is precisely computer controlled.

## CHARACTERISTICS

- Voltage:120VAC/240VAC
- Power: 1700 Watt Max
- Plate (6) OD: 188mm
- Mode of Operation: Continuous
- Adjustable Timer
- Adjustable Thermostat
- Net Weight: 9.3Kg
- Gross Weight: 10.5Kg
- Size: 480 x 232 x 234mm
- Carton: 515 x 350 x 320mm

## STRUCTURE AND DIAGRAM

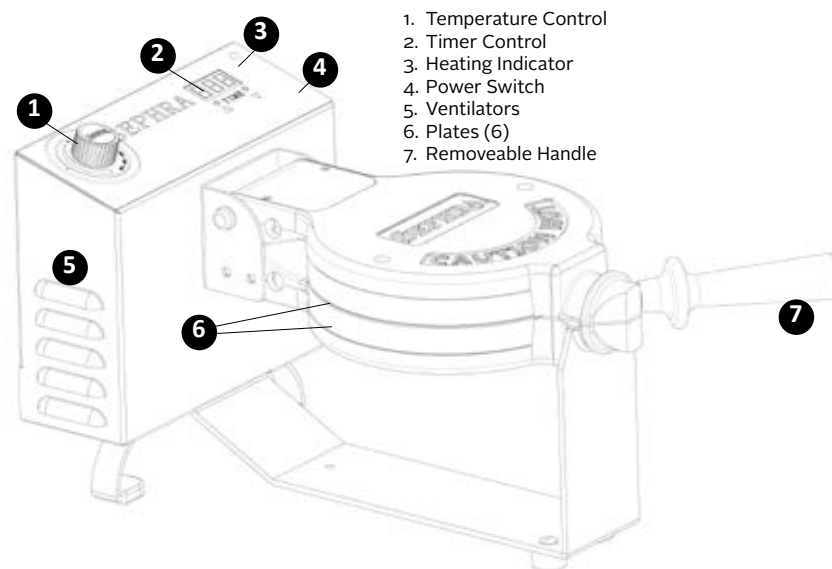

# APPLIANCE INSTRUCTIONS

## WORK SURFACE

Choose an easy-to-clean work surface on which to install the appliance.

The appliance must be at least 20cm from any vertical surfaces that are not heat-resistant in order to prevent damage by heat radiating from the Plates (6).

To ensure maximum ease of use, the top of the irons should be between 85 and 95cm from the ground.

# BEFORE FIRST USE

The Baking Plates (6) become very hot during operation. Use the unit only for the explicit purposes, i.e. for baking and cooking cake mixtures (with wheat flour, potato flour or wholemeal flour). We strictly advise against inappropriate use.

**Do not use the Baking Plate (6) for heating up pots or pans.**

**Do not cover the Baking Plates (6) with aluminium foil.**

**Do not place plastic basins onto the Baking Plate (6).**

## INSTRUCTIONS

1. Make sure this appliance is plugged into electrical outlet which has a voltage and amperage rating that matches the rating Plate (6) on the back of the unit.
2. Place the appliance on flat and solid surface. Use the Handle (7) to rotate the Plates (6) and make sure it turns smoothly.

Note: It is common that the rotation can feel tight to turn for the first use. Try rotating the Plates (6) several times to loosen it.

## IMPORTANT

The Waffle Maker becomes very hot although it does not appear to be. Therefore, we advise you to be very careful when placing anything onto the Baking Plate (6). Take care at filling the Waffle Mix into the mould that the upper Plate (6) has been opened as far as the stop. After filling the Waffle Mix onto the lower Plate (6), the unit is closed by lowering the upper Baking Plate (6). Then adjust the Timer (2) to the demanded minutes.

When the time is over, the Timer (2) beeps and the Waffle is ready.

We advise you to dispense exactly the recommended quantity of Waffle Mix onto the Plate (6). Otherwise the residual liquid mix would be pressed out of the sides of the Plates (6) and will smudge your device. During the baking procedure it might happen that steam escapes from the unit. Avoid close contact with the steam otherwise it might cause burnings. For this reason the unit should only be opened and closed by means of the insulated Handle (7). Remove the finished baking products only by using the appropriate utensils such as heat-resistant plastic, silicone or wooden spatula. **Do not touch the Plates (6) with bare hands.**

## CLEANING

Only clean this unit with a Sephra Soft Brush or similar one.

**Do not use abrasive detergents or sharp objects to clean.**



# OPERATING INSTRUCTIONS

<b>STEP 1</b>	Connect your machine to a power supply then turn on the Power Switch (4) and the LED Digital Timer (2) will turn on and the machine will beep once.
<b>STEP 2</b>	Set the desired temperature using the adjustable Thermostat (1) (we recommend between 180 – 200°C). The heating indicator on the top right will turn off when the desired temperature has been met this will take approximately 12-15 minutes. Using the up and down arrows under the Digital Timer (2) set the desired cooking time we recommend between 120 – 180 seconds but this will vary with different batter mixes and how crispy you would like your Waffle to be.
<b>STEP 3</b>	Lift the top Plate (6) and pour 135-145g of prepared Waffle Mix into the centre of the lower Plate (6). Close the Plates (6) together and rotate the Handle (7) clockwise 180 degrees to start the Timer (2) for the Waffle making process. You can see how long your Waffle has to cook as the Digital Timer (2) counts down to zero.
<b>STEP 4</b>	When the Waffle is ready you will hear 5 beeps and the Digital Timer (2) will reset to the original cooking time indicating that you need to remove your Waffle from the Plates (6). To remove the Waffle rotate the Handle (7) counter clockwise 180 degrees to its original position. Open the Plates (6) and remove the Waffle by gently loosening the edges with a heat-resistant plastic, silicone or wooden spatula. Do not use metal utensils near the Plates (6) to avoid damaging the non-stick coating!
<b>STEP 5</b>	To make your next Waffle simply go to <b>STEP 3</b> .

Close the top Plate (6) while preparing for the next Waffle.

## SAFETY

The unit described in this operating becomes hotter than 60°C. Please follow our instructions in order to avoid burning yourself.

## CAUTION

Operate the unit at an appropriate distance and make sure that your arm or your hands do not come into contact with the black Plate (6) carrier or the Plates (6) themselves.

We advise holding the Handle (7) of the upper Plate (6) with one hand, while using the other hand to remove the Waffle. Do not pour water onto the hot Plates (6) or place any pots or metallic container onto the Plates (6).

For hygienic and safety reasons we recommend you to use wrist covering gloves. Always make sure not to touch the hot units with bare fingers or hands.

**Do not touch the hot food with bare hands.**

# REPLACEMENT PLATE INSTRUCTIONS

## IMPORTANT STATEMENT

The Plates (6) are consumable wear item parts and are not covered by the warranty. Please contact the manufacturer to purchase new Plates (6) when necessary and follow the Plates (6) replacement instruction to install.

1. Warning! Allow machine to cool and unplug the Waffle Maker prior to proceeding.
2. Rotate the Handle (7) to turn over the Plates (6) (the Handle (7) should be on the left).
3. Remove the screws on the top surface of the bottom Plate (6) carrier pedestal.
4. Rotate the Handle (7) to turn back the Plates (6) (the Handle (7) should be on the right)
5. Remove the screws on the top surface of the top Plate (6) carrier pedestal.
6. Slowly open the top pedestal and remove the top Plate (6). If it sticks, please pry the gap lightly.
7. Remove the bottom Plate (6). Please keep the top pedestal in place to avoid hand injury. Take caution to lift the bottom Plate (6) straight upward not to damage the temperature sensor and to avoid equipment damage as a result.
8. Install the new bottom Plate (6) first. The Plates (6) should be pressed down flush (no gap) to the Plate (6) carrier pedestal. If it is tight, please check the position of the two temperature sensors and align the screw holes with the thread locations and until the Plate (6) can be pressed down smoothly.
9. Replace the prior removed screws and tighten snugly.
10. Install the new top Plate (6) in the same manner to be certain the screw holes are aligned with the thread locations and the Plate (6) can be pressed down flush (no gap) with the Plate (6) carrier pedestal.
11. Close the top pedestal and you are ready to use the Waffle Maker again.

# EUROPEAN READY MIX & CLEANING GUIDE

Sephra Waffle Mix comes in convenient 3Kg bags. All you need is water for this simple and easy recipe. 3Kg of this Waffle Mix will make approximately 30 - 35 Waffles depending on the style of Waffle you are cooking. This mixture is perfect for high output stores. It is as convenient, easy to use and delicious as any home made mixture.

## WAFFLES

1000g Premix

800g Water

## INSTRUCTIONS BASED ON 1KG PREMIX

These instructions are intended as a guide and may require changes to fit individual baking conditions. Store in a cool dry place (max 21°C).

**Allergen advice:** This product contains **Wheat, Egg, Milk** and **Soya**.

## MIXING METHOD

1. Slowly add water to premix.
2. Mix at a slow speed for 1 minute - scrape down.
3. Mix medium speed for 3 minutes.
4. Cook Waffle at the desired temperature recommended to 180- 200°C.
5. Deposit 135 - 145g of batter into the Waffle Maker.
6. Cook Waffle for 120 - 180 seconds or until you have the desired colour.
7. Finish and Serve.

## MAINTENANCE AND CLEANING

- Clean the frame with a sponge dipped in warm water and diluted liquid detergent
- Do not use abrasive products or metallic brushes.
- Do not clean the appliance under flowing water.
- Do not immerse the appliance.
- Due to the high temperature of the appliance, it is normal for the stainless steel to turn brown in time.

Disconnect from power supply and wait until the unit has cooled down before you begin maintenance or cleaning procedures. Food residues or spots on the surfaces have to be cleaned immediately (make sure not to burn yourself as it could still be hot) or at the latest before operation. Use a dry cloth for cleaning if only slight residues have to be removed. If this is not sufficient, please wait until the unit is cool and clean with a non-abrasive detergent.

# USA READY MIX & CLEANING GUIDE

These instructions are intended as a guide and may require changes to fit individual baking conditions. Sephra Waffle Mixes come in convenient 5lb bags. All you need is water for this simple and easy recipe. A 5lb bag of the Belgian or Bubble Waffle Mix will make approximately 30 - 35 7" Waffles depending on the style of Waffle you are cooking and the baker you are using. Both mixtures are perfect for high output stores, as they are convenient, easy to use and as delicious as any homemade mixture. Store in a cool dry place (max 65°F / 18°C).

## **BELGIAN WAFFLES 5LB MIX - 2L / 8.5 CUPS COLD WATER**

### **MIXING METHOD**

1. Gradually add one 5lb bag of Belgian Waffle Mix & whisk until smooth.
2. For smaller batches, remember 90% water to 100% Mix.
3. Preheat your Belgian Waffle Baker according to the manufacturer's instructions.
4. If using a Sephra Baker pour approximately 5oz of mixed batter onto the baker & cook for 2 minutes. Add toppings as desired.

**Allergen advice:** Belgian Waffle Mix contains **Wheat, Corn** and **Soya**.

## **BUBBLE WAFFLES 5LB MIX - 2.2L / 9 ⅔ CUPS COLD WATER**

### **MIXING METHOD**

1. Gradually add one 5lb bag of mix & whisk until smooth.
2. Let finished mix rest for 10 mins then stir again.
3. For smaller batches (6 Waffles), use 24oz (3 cups) of mix with 16oz (2 cups) of cold water.
4. Preheat your Waffle Baker according to the manufacturer's instructions.
5. To make a 7" Waffle pour approximately 5oz (⅔ cup) of mixed batter onto the baker & cook for 2 mins and 30 secs. Add toppings as desired.

**Allergen advice:** Bubble Waffle Mix contains **Wheat, Egg,** and **Soy**.

## **MAINTENANCE AND CLEANING**

- Clean the frame with a sponge dipped in warm water, never use abrasive products or metallic brushes.
- Do not clean the appliance under flowing water, do not immerse the appliance.
- Due to the high temperature of the appliance, it is normal for the stainless steel to turn brown over time.

Disconnect from power supply and wait until the unit has cooled down before you begin maintenance or cleaning procedures. Food residues or spots on the surfaces have to be cleaned immediately (make sure not to burn yourself as it could still be hot) or at the latest before operation. Use a dry cloth for cleaning if only slight residues have to be removed. If this is not sufficient, please wait until the unit is cool and clean with warm water.

## AFTERSALES GUARANTEE

This appliance is guaranteed for one year on a "return to base" warranty.

We pay great attention to ensure that each of our appliances reaches the user in perfect operating condition. If you do find a problem when unpacking your appliance, please report it to the shop within 48 hours.

If you are confronted with faulty operation during the guarantee period, please contact your dealer. No damage due to incorrect use or failure to comply with the instructions is covered by the guarantee. Please do not hesitate to let us have your suggestions.

The symbol representing a waste-bin crossed out and shown on the product or its packaging indicates that this product must not be treated as ordinary household waste. It must be taken to the appropriate collection centre for recycling of electrical and electronic equipment:

- to a point of sale if an equivalent item of equipment is purchased.
- to a collection point made available in your neighbourhood (waste collection centre, selective waste collection, etc.).

By making sure that this product is disposed of in appropriate fashion you will help prevent any potentially negative consequences for the environment and human health.

Recycling of the materials will help preserve natural resources.

For any further information concerning recycling of this product, you can contact your local authorities, waste collection centre or the shop where you purchased the product.

# NOTES

# NOTES

# SEPHRA<sup>®</sup>

CATERING EQUIPMENT AND SUPPLIES

Sephra Head Office - Sephra House, Denburn Road, Kirkcaldy, Fife, Scotland KY1 2BJ  
Tel: +44 (0)1592 656 737 / Fax: +44 (0)1592 653 535  
Web: [www.sephra.com](http://www.sephra.com) / Email: [info@sephra.com](mailto:info@sephra.com)

Sephra USA LLC - Tel: +1 858 675 3088 / Web: [www.sephrausa.com](http://www.sephrausa.com) / Email: [info@sephrausa.com](mailto:info@sephrausa.com)